

1570 CBU SERIES VIEW WITH INSTALLED ACCESSORIES

MULTI-UNITS PAD SPECIFICATION

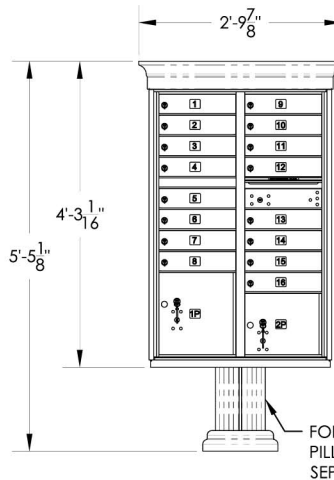

CLEAN COMPLETE UPPER SURFACES WITH A DAMP CLOTH THEN WIPE DOWN FRONT AND REAR TOP EDGES WITH ALCOHOL PAD

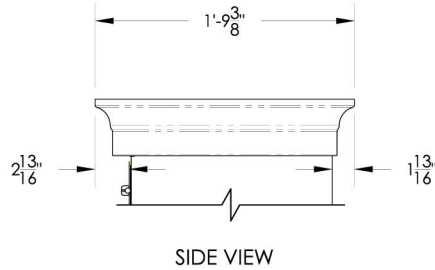
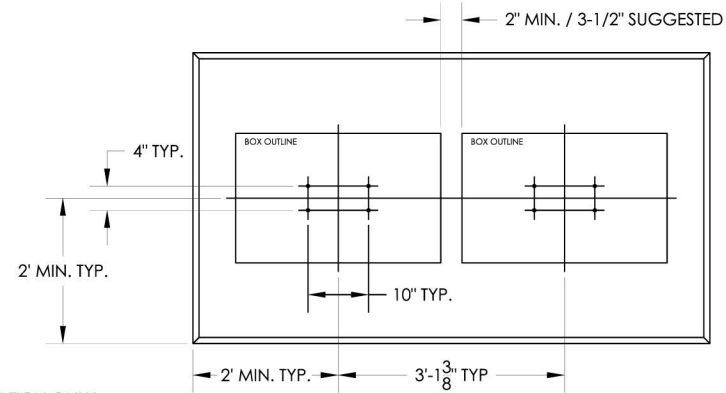
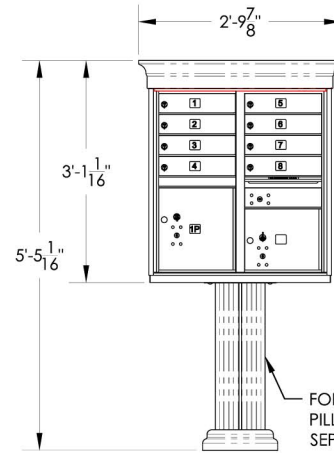
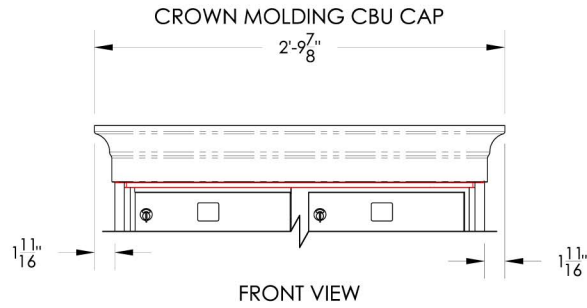
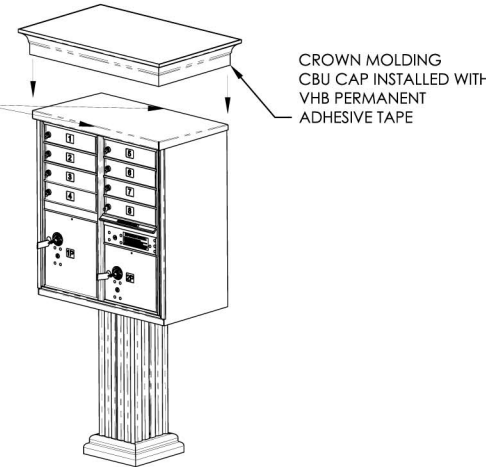

IMPORTANT CLEARANCE SPEC
SEE MULTI UNIT PAD SPECIFICATION
FOR BOLT PATTERN AND SPACING

NOTES:

1. CROWN MOLDING CAP DESIGN REQUIRES ADDITIONAL SPACE BETWEEN CBUs FOR MULTIPLE CBU INSTALLATIONS. SEE IMPORTANT CLEARANCE SPEC ABOVE.
2. CAP AND PEDESTAL COVER SOLD SEPARATELY.
3. CROWN MOLDING CAP AVAILABLE IN ALL STANDARD CBU POWDER COAT FINISHES.
4. CAP INSTALLED USING PERMANENT VHB ADHESIVE TAPE. NO HARDWARE NECESSARY.
5. CROWN MOLDING CAP DESIGNED TO FIT OVER FLORENCE 1570 SERIES CBU.

PRODUCT SERIES: VOGUE™ CBU ACCESSORIES

The Mailbox Works
800-824-9985
www.MailboxWorks.com

MODEL	CROWN MOLDING CAP	REV	-
SCALE	NONE	DATE	1/1/2008
DRAWING NUMBER	VOGUEC1CS	DRAWN BY	AFD
		SHEET	1 OF 1